

Healthy Vision at the Computer



www.aoa.org

Vision & Lifestyle

People who sit in front of a computer for long periods of time often encounter a variety of uncomfortable symptoms. Headaches, neck strain, backaches and wrist pain are common, but, sadly, the most prevalent symptoms of prolonged computer use—eye strain, blurred vision and dry eye—are often overlooked. In fact, eye and vision problems are the most frequently reported health care problems among computer users.

Computer Vision Syndrome

These symptoms contribute to computer vision syndrome, which the American Optometric Association defines as “the complex of eye and vision problems related to near work that are experienced during or related to computer use.”

Sitting at a computer generally causes a person to look straight ahead for long stretches, work in a dry office or home environment, and to blink less often. These factors can lead to vision problems. Additionally, computer use requires specific vision skills, which add further demands to the visual system and contribute to eye and vision discomfort. These skills include:

- **Ocular motility**- the ability of the eyes to move in various positions.
- **Accommodation**- the ability of the eyes to focus clearly at various distances.
- **Vergence**- The ability to move the eyes in (convergence) or out (divergence).

Effects of Working Environment

Computer work places various demands on the visual system. Each of these factors can play a part in computer vision syndrome.

- **Screen resolution**- Better resolution offers greater clarity and usually leads to improved comfort. Adjust the resolution to the highest resolution your monitor will support. If the increased screen resolution makes items too small, try increasing the font size (DPI) to compensate.
- **Screen contrast**- Adjust the contrast between the characters on the monitor and the background so the letters are easily read. Adjust the brightness of the monitor to an intensity that is comfortable to your eyes--not too bright and not too dim. Adjust both brightness and contrast for the best clarity.
- **Screen glare and reflections**- Minimize reflected glare on your monitor by using window treatments, dimmer switches on lights and glare reduction filters. Look for glare reduction filters that have received the American Optometric Association Seal of Acceptance. Proper adjustment should eliminate any reflected images from the monitor screen. To reduce glare, eliminate bright light sources from your peripheral vision and position your monitor perpendicular to windows or other bright light sources.

- **Image refresh rates and flicker**- A higher refresh rate for your monitor is best. The image on the screen should not flicker at all. (This is not a concern with LCDs.)
- **Working distances and angles**- It is important to work at a distance that is comfortable for you and where the image on the screen is clear. Having to move your head to an awkward angle to see the screen clearly suggests that your prescription may need adjustment.

(Continued on back)

Is Your Work Station Properly Arranged?

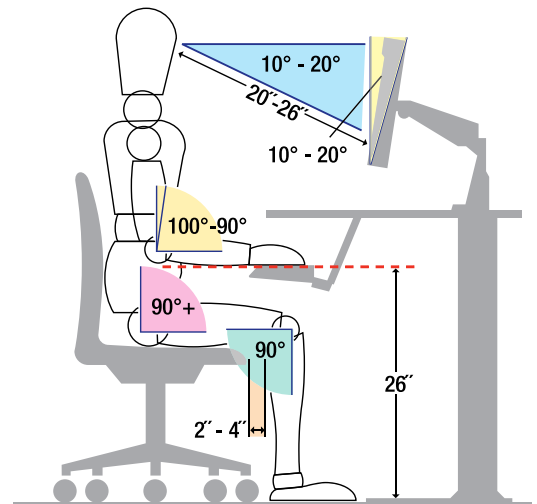

American Optometric Association

■ **General eyeglass prescription may not be adequate-** Computers are usually further and higher than a typical reading task. Glasses for most people wearing bifocals are not adjusted for this new distance or angle and therefore often are not adequate for using the computer.

■ **Repetitive and stressful tasks-** Difficult tasks are challenging. Don't forget to take occasional breaks and let the eyes look far away while resting.

Tips for Healthy, Comfortable Vision at the Computer

While decreasing time spent at a computer may not be an option, there are ways to maximize healthy vision for comfortable use of the computer.

■ Have a regular comprehensive eye exam to ensure your eyes are healthy and that you have the correct eyeglass or contact lens prescription (if necessary). Be certain to tell your optometrist about the computer work you do.

■ Wear glasses that are specifically designed to function comfortably at the computer. The lenses you wear for day-to-day activities may not be the best for working at the computer.

- Rest the eyes
- Blink forcefully
- Use a humidifier
- Instill artificial tears

After you have had a comprehensive eye examination, there are a number of things that you can do to arrange and use the elements of your workstation to eliminate or minimize discomfort.

Workstation Setup for Comfortable Computer Use

■ Feet should be flat on the floor (or on a slightly angled foot rest) with knees bent close to or greater than 90 degrees.

■ Chair seat should support the legs without excessive pressure on the back of the thighs.

■ The back should be snug against the seat to fit your spinal contour. Thigh-to-trunk angle should be 90 degrees or greater.

■ Wrists and hands should extend nearly straight from the elbow to the home row of the keyboard.

■ A commonly preferred work surface height for keyboard use is about 26" as opposed to the conventional 29" of most tables or desks.

■ Place the monitor 20"-26" from your eyes, depending on the size of the monitor and individual vision conditions.

■ The monitor and keyboard should be straight ahead.

■ The top of the monitor should be slightly below horizontal eye level. Tilt the top of the monitor away from you at a 10 degree to 20 degree angle. The center of the monitor should be 10 degrees to 20 degrees below your eyes. This is 4"-9" below your eyes at a distance of 24".

■ Keep the monitor free of fingerprints and dust. Both can reduce clarity.

■ Place document holders close to the screen within the same viewing distance. Keep the keyboard and monitor in line.

■ Adjust the keyboard tilt angle so that wrists are straight.

Healthy Computer Use

Although the visual system faces considerable challenges when using a computer, most issues can be solved. Remember that problems with the use of the computer cause needless discomfort and may rob productivity. Heeding the suggestions made here along with those made by your doctor of optometry, will enable you to use your computer comfortably and productively.

Compliments of: